

# SICC 112

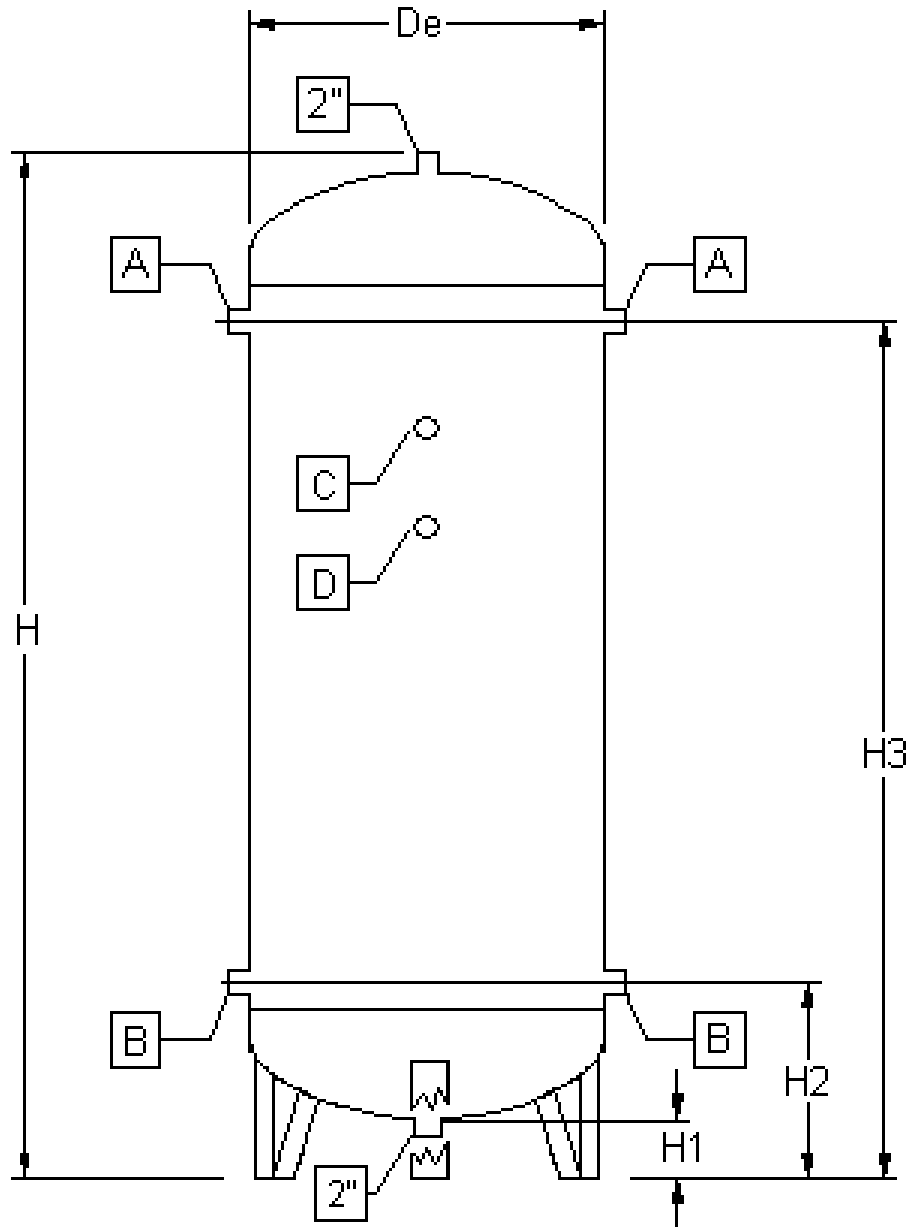

TIPO	BAR	De	H	H1	H2	H3	A-B	C	D
200	11	430	1540	132	400	1360	3/4"	3/8"	1/4"
270	11	500	1670	175	445	1430	3/4"	3/8"	1/4"
500	11	600	2060	155	705	1705	1"1/2	3/4"	3/8"
725	10,8	790	1800	137	690	1440	1"1/2	3/4"	3/8"
900	11	790	2160	146	800	1800	2"	3/4"	3/8"

# SICC 212

MOD.	Ps (Bar)	D	H	h	a-b	Aperture d'ispezione (Optional)		L	m
1000	11,5	790	2345	200	2"	PM 100x150	PU 300x400	725	1725
1500	11,5	1000	2305	180	2"	PM 100x150	PU 300x400	590	1860
2000	11,5	1000	2805	180	2"	PM 100x150	PU 300x400	595	2355
3000	11,5	1200	2965	185	3"	PM 100x150	PU 300x400	700	2410
4000	11,5	1450	3070	180	3"	PM 100x150	PU 300x400	780	2430
4000VL	11,5	1200	3990	210	3"	PM 100x150	PU 300x400	735	3425
5000	11,5	1450	3570	180	3"	PM 100x150	PU 300x400	780	2930
5000VL	11,5	1200	4990	210	3"	PM 100x150	PU 300x400	735	4425
6000	11,5	1450	4070	180	3"	PM 100x150	PU 300x400	780	3430
8000	11,5	1650	4135	145	4"	PM 100x150	PU 300x400	820	3415
10000	11,5	1650	5135	145	4"	PM 100x150	PU 300x400	820	4415

